

The new JUNO®bed - Safely classic

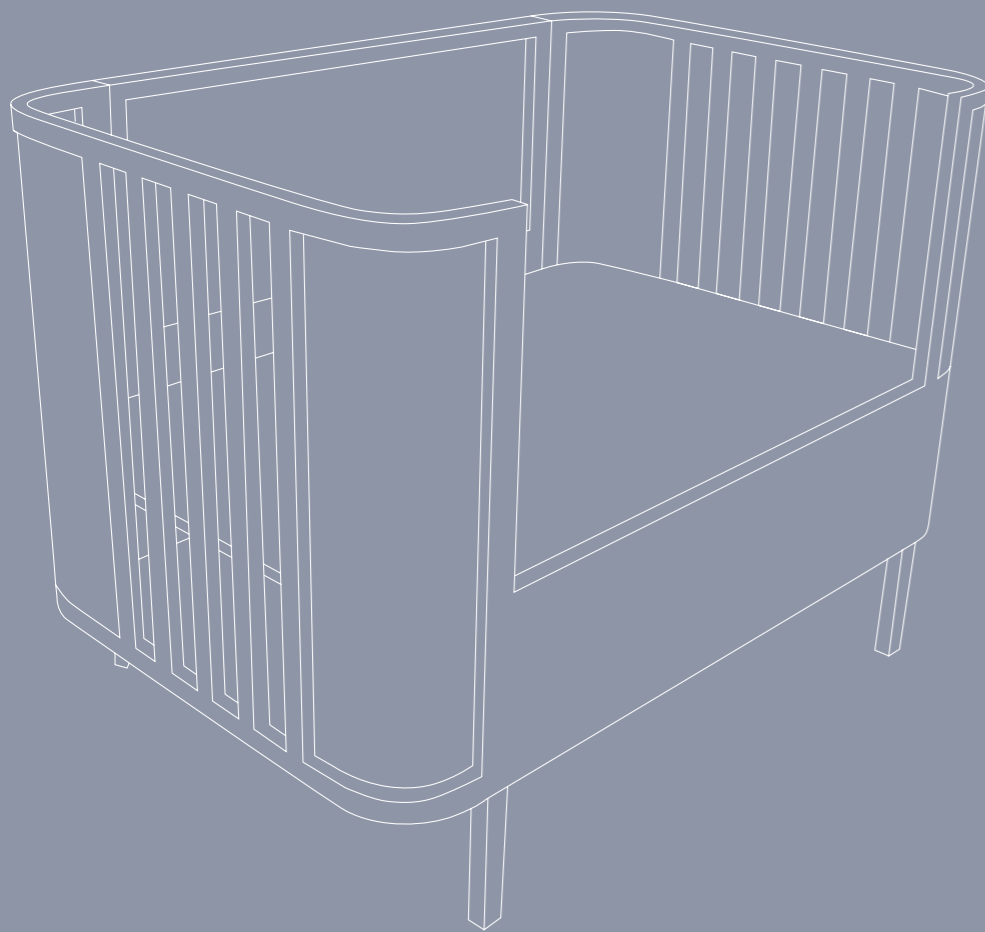

JUNO

JUNO ApS

Ringstedvej 20
DK - 4520 Svinninge

Tel: +45 59 26 10 56
Fax: +45 59 26 10 49

info@alt-til-baby.dk
www.alt-til-baby.dk

JUNO



When a classic moves with the times

With the new JUNO®bed your child can sleep in a bed which is at once classic ... and safe. Especially the latter is what separates the new from the old Juno, which was created in 1942-43 by the architect Viggo Einfeldt. While the first one would not be able to attain the safety certificates of our day, the new JUNO®bed is certified by all current standards in the entire EU. That is why we do not hesitate to call it “safely classic”.

Let the child sleep in the best there is

When we were starting production of the new JUNO®bed, we adhered to the strictest rules for safe children's beds. This means that we now know everything about break-age points, bar height, edges and spaces. We looked at the first JUNO, and determined it's strong and weak points. Then we experimented our way forward, testing several prototypes, until the new JUNO®bed took it's final form. True to it's role model - and not least true to safety, quality and function.

When your child grows, the new JUNO®bed grows with it

When you purchase your new JUNObed, you receive everything needed for it's three life stages - including mattresses - so that you can use the bed from infancy up to and including 7 years of age. The transformation happens with just 4 screws.

A Danish bed through and through

Everything from top to bottom, from legs to mattress, plates and screws, is made in Denmark - adhering to the finest traditions of craftsmanship and design. This makes the new JUNO®bed cost a bit more than other beds. In return the quality is high, leaving no doubt that this is a sturdy - and safe - bed, which can be used for many years to come.

A bed with room for personality

The acrylic glass sides not only makes the bed easy on the eyes. They also allow the little one to look out and discover the world. The acrylic glass can be had with or without motif - if for example you should wish to try your own hand at decorating with pictures, drawings or other cute details. If you choose the motif, you get the same bed which the royal Danish court chose for the Crown prince couple's son, H.R.H. Prince Christian.

The first Juno was ahead of it's time. But now, it's time has run out

Viggo Einfeldt was ahead of his time with the first Juno. He was also thinking in terms of safety for the child - the same way that we have done with the new JUNO®bed. But where the first bed now no longer lives up to the demands, we have improved it all around, so that you can let new generations of children sleep, safely classic, and in good conscience.

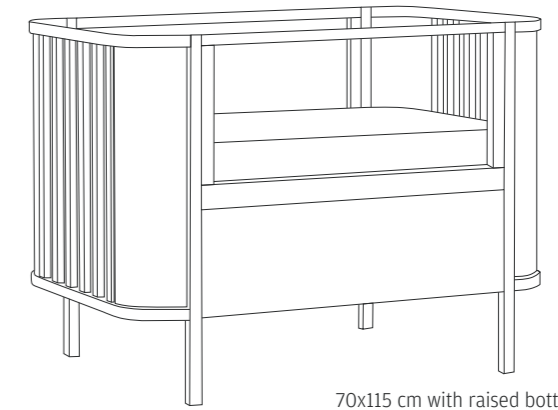

70x115 cm with raised bottom and sides

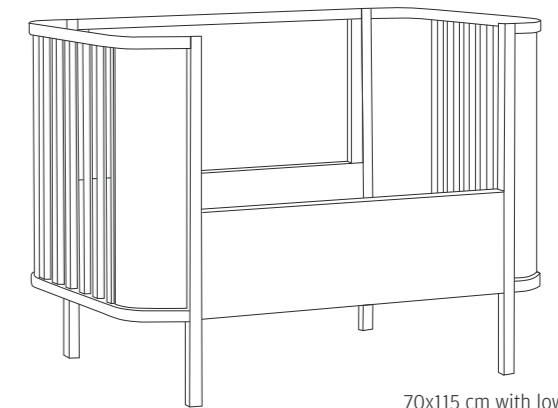

70x115 cm with lowered bottom

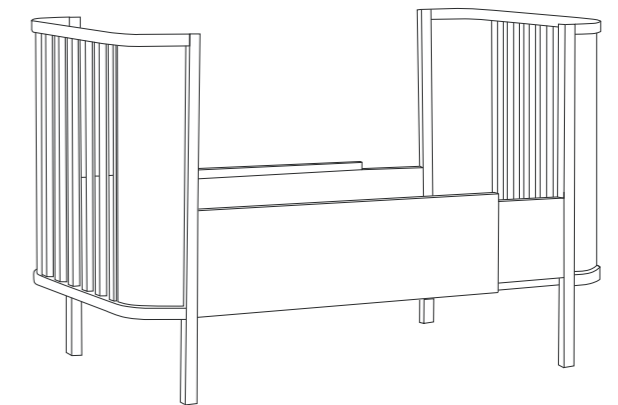

120 cm long

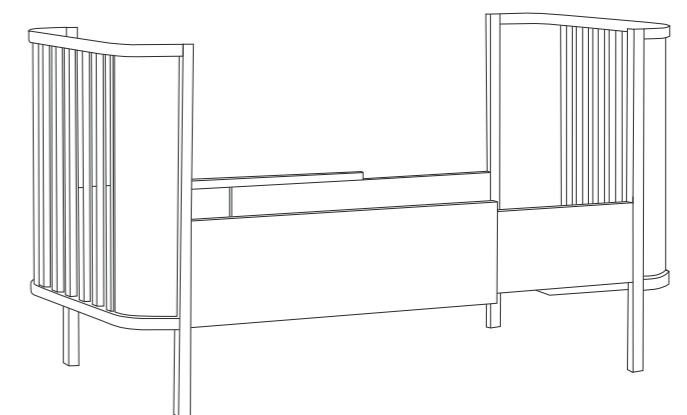

150 cm long